

Measuring authentic living from internal and external perspectives: A novel measure of self-authenticity

Item Type	Article
Authors	Cartwright, Tim;Hulbert-Williams, Lee;Evans, Gemma;Hulbert-Williams, Nick
Citation	Cartwright, T., Hulbert-Williams, L., Evans, G., & Hulbert-Williams, N. (2023). Measuring authentic living from internal and external perspectives: A novel measure of self-authenticity. <i>Social Sciences & Humanities Open</i> , 8(1), 100698. https://doi.org/10.1016/j.ssaho.2023.100698
DOI	10.1016/j.ssaho.2023.100698
Publisher	Elsevier
Journal	<i>Social Sciences & Humanities Open</i>
Rights	Attribution-NonCommercial 4.0 International
Download date	2026-05-10 17:08:53
Item License	https://creativecommons.org/licenses/by-nc-nd/4.0/
Link to Item	http://hdl.handle.net/10034/628257



Regular Article

Measuring authentic living from internal and external perspectives: A novel measure of self-authenticity

T. Cartwright^{*}, L. Hulbert-Williams, G. Evans, N. Hulbert-Williams

The University of Chester, Parkgate Rd, Chester, CH1 4BJ, UK

ARTICLE INFO

Keywords:

Self-Authenticity
Authentic living
Valued living
Psychological flexibility

ABSTRACT

Self-authenticity refers to knowing and being oneself despite societal expectations, a concept closely related to values-based therapeutic interventions. Authentic living is currently measured using three validated psychometric scales; however these have limitations including issues with length, theoretical instability, and lack of measurement invariance testing. The present study sought to develop a novel measure of self-authenticity to resolve these limitations, and to provide further empirical evidence as to the structure of self-authenticity. Using a large sample, split into two subsamples, the novel Self-Authenticity Measure (SAM) was developed and found to be reliable. We present evidence of convergent and concurrent validity, as well as a degree of incremental validity over one of the previously developed authenticity scales. Furthermore, construct validity and (configural) measurement invariance were demonstrated through confirmatory factor analysis. Thus, though the measure was initially developed for use with sexual-minority groups, it appears to function similarly in a heterosexual sample. Self-authenticity correlated with constructs related to psychological flexibility, suggesting that therapeutic techniques based on valued living could increase self-authenticity in individuals. The SAM affords researchers the opportunity to measure self-authenticity from internal (knowing and being oneself) and external (being oneself around others) perspectives. Further testing of measurement invariance is recommended.

1. Introduction

Self-authenticity is a complex psychological phenomenon, and while the nature and definition of what it means to be authentic have been widely debated from multiple philosophical viewpoints (see Guignon, 2008; Harter, 2002; Rowan, 2000; Stefan, 2016), in this paper we adopt Varga's (2014, pp. 215–225) definition that the authentic individual is one who is living "in accordance with desires, motives, ideals or beliefs that are not only hers (as opposed to someone else's), but that also express who she really is" (p. 215). Living authentically is not without its complexities, particularly given the social environment, often requiring individuals to negotiate the boundaries of authentic self-expression within a society that may disapprove of such self-expression (for a discussion, see Pietikainen, 2002, Guignon, 2008, Wood et al., 2008, Varga, 2014, Stefan, 2016). To take one example, this issue may be particularly relevant to sexual minorities who may embrace their identity, resulting in minority stress from experiences of prejudice and discrimination (Levitt et al., 2016; Meyer, 1995). Ultimately, authentic living needs to be understood within social contexts (Gardner & Prasad, 2022; Harter,

2002).

A recent meta-analysis (Sutton, 2020; $N = 18,637$) suggests that living authentically is moderately related to psychological wellbeing, and from the perspective of clinical, therapeutic, and coaching psychology, having an adequate measure of self-authenticity may provide considerable utility. To our knowledge there exist three measures of authenticity; the Authenticity Inventory (Kernis & Goldman, 2006), the Authenticity Scale (Wood et al., 2008), and the Moscow Authenticity Scale (Reznichenko et al., 2021).

The Authenticity Inventory (Kernis & Goldman, 2006) measures four aspects of authenticity: awareness (awareness, knowledge, and trust in the self), unbiased processing (objectivity in the assessment of one's self), behaviour (behaving in line with one's needs and values), and relational orientation (achieving truthfulness and openness in relationships). The authors report acceptable to excellent internal consistency for each subscale ($\alpha = 0.64$ to 0.80 ; composite $\alpha = .90$), good test-retest reliability ($r = 0.69$ to 0.80 ; composite $r = .87$), and evidence of concurrent validity with self-esteem ($r = -0.37$ to 0.56), however little detail was provided on the participant samples with whom these

^{*} Corresponding author.

E-mail addresses: tim.cartwright@chester.ac.uk (T. Cartwright), l.hulberwilliams@chester.ac.uk (L. Hulbert-Williams), gemma.evans@chester.ac.uk (G. Evans), nick.hulbert-williams@edgehill.ac.uk (N. Hulbert-Williams).

<https://doi.org/10.1016/j.ssaho.2023.100698>

Received 3 May 2023; Received in revised form 11 September 2023; Accepted 30 September 2023

Available online 10 October 2023

2590-2911/© 2023 The Authors. Published by Elsevier Ltd. This is an open access article under the CC BY-NC-ND license (<http://creativecommons.org/licenses/by-nc-nd/4.0/>).

measures were developed. The 45-item measure may be considered impractical and burdensome for research and real-world use. Some of the items are long and appear to measure aspects of psychological wellbeing and quality of relationships, not entirely matching the above definition of authenticity. A revised 20-item short form has been developed (Bond et al., 2018) using a sizeable sample, and which demonstrates good internal consistency and good concurrent and convergent validity with measures of psychological wellbeing and personality. Whilst Bond and colleagues make an excellent contribution, their reporting neatly illustrates the considerable number of researcher degrees of freedom inherent in any measure development process (see Flake & Fried, 2020). For example, no pre-specified cut-offs are provided for the selection and rejection of items. This is not to criticise these authors, but to highlight a general point in measure development, and one which leads to the necessity for multiple attempts by multiple teams in order that science may triangulate amongst these attempts and reach firm conclusions.

The Authenticity Scale (Wood et al., 2008) measures three aspects of authenticity: authentic living (the coherence between conscious awareness, behavioural, and emotional expression), accepting external influences (accepting the influence of others and conforming to their expectations), and self-alienation (the incongruence between conscious awareness and physiological/emotional states). The authors report acceptable to good internal consistency for each subscale ($\alpha = 0.70$ to 0.84), good test-retest reliability ($r = 0.78$ and 0.91), as well as concurrent validity with self-esteem ($r = -0.20$ to -0.59), satisfaction with life ($r = 0.21$ to -0.50), positive affect ($r = 0.17$ to -0.35), and negative affect ($r = 0.18$ to 0.49). Some psychometric development manuals suggest that a sample size of at least 300 participants, or 10 participants per item, is needed for a methodologically robust psychometric development study (Field, 2013; Tabachnick et al., 2013); as such the factor analytic work for the Authenticity Scale is potentially underpowered (200 participants over 25 items). This would likely lead to inadequate factor recovery (de Winter et al., 2009). Furthermore, as recommended by Guadagnoli and Velicer (1988), the authentic living subscale lacks the minimum four items loading greater than 0.6, indicating this factor may be unstable in future samples.

The Moscow Authenticity Scale (Reznichenko et al., 2021) is a short measure of authenticity that was developed and then further tested using confirmatory factor analysis (CFA). The authors report good internal consistency ($\alpha = 0.76$) and convergent validity with the three subscales of the Russian version of the Wood et al. (2008) Authenticity Scale ($r = -0.45$ to -0.67) which was adapted following the guidelines for effectively translating instruments. As regards psychometric development, Reznichenko et al. (2021) note that a more complete validation study of both Russian and English versions of the measure is needed, including other forms of validation and testing of measurement invariance, particularly as the measure was developed using a student-only, female-dominated sample within Moscow.

Given the limitations of these existing measures, a novel measure of self-authenticity is warranted, and specifically one that includes a full and in-depth validation procedure. Furthermore, as self-authenticity is related to living closely by one's values (Sheldon & Kasser, 2001; Varga, 2014), it would be beneficial to re-examine the construct of self-authenticity in light of the most recent literature on valued living. Encouraging values-based living through therapeutic intervention has been widely promoted across the domain of psychotherapy, not least by Fritz Perls (Rowan, 2000), Carl Rogers (Harter, 2002; Plumb et al., 2009; Sheldon & Kasser, 2001; Wood et al., 2008), and Eugene Gendlin (1984). Today, therapists often encourage clients to consider their personal values, personal conflict within the context of societal expectations, and to consider and discover how to live more authentically (Plumb et al., 2009; Sheldon & Kasser, 2001). One such type of therapy is Acceptance and Commitment Therapy/Training (ACT). As a third wave therapy, ACT encourages clients to engage in values-based living through increasing their psychological flexibility (for reviews, see Hayes, 2004,

Hayes et al., 2006, Hayes et al., 2011; Reilly et al., 2018). It is plausible therefore that a relationship will exist between self-authenticity and psychological flexibility processes.

To serve as further justification for the need for this novel measure, we would argue that the measure development process is not a one-off exercise conducted by a single team, nor even something that can be completed in a small number of attempts, but an iterative, multi-team endeavour aimed at achieving a robust understanding of a construct's structure. The Big 5 model serves as an exemplar in this context. The model was not the result of a single study, nor even a handful, but emerged from extensive triangulation across various researchers, settings, cultures, and samples (Digman, 1990). Multiple iterations of item pool generation, exploratory factor analysis, and CFA were conducted to scrutinise and refine the construct's dimensions across a broad literature. This rigorous, repetitive process conducted by diverse teams over an extended timeframe helped establish the Big 5 as a universally accepted model for understanding personality. We say this to draw a parallel with the present work as we believe more attempts to develop authenticity measures across diverse samples are needed before we can begin to have confidence as to the modelled structure of this construct. The current work was conducted as part of a larger project examining self-authenticity and minority stress in people who belong to a sexual minority. This provides an opportunity to develop a scale and test the structure of self-authenticity in a manner that adds to the diversity of the evidence base.

1.1. Study aims

The aim of this study was to use a comparatively more rigorous and high-quality approach to develop the novel Self-Authenticity Measure (SAM) and conduct reliability and validity testing, including CFA using a secondary subsample of participants to test for measurement invariance. Given the above discussion relating to the overlap between the concepts of personal values and self-authenticity, we also used these data to test the hypothesis that self-authenticity would significantly correlate with psychological flexibility processes.

2. Method

2.1. Study design

Two online cross-sectional surveys (time 1 and time 2, seven days apart) were developed. At time 1 we measured self-authenticity, authenticity, psychological distress, psychological flexibility, and engaged living, and at time 2 we measured self-authenticity, fear of negative evaluation, and self-esteem. The study was hosted on www.onlinesurveys.ac.uk, and was advertised using social media platforms including Facebook and Twitter. Ethical approval was granted by the School of Psychology Ethics Committee at our university.

2.2. Participants

A total of 1073 individuals participated in the study. Two subsamples were recruited: participants identifying as a sexual minority ($n_1 = 708$; $M_{age} = 28.74$, $SD_{age} = 11.57$) for measure development, and participants identifying as heterosexual ($n_2 = 365$; $M_{age} = 32.68$, $SD_{age} = 12.66$) for measurement invariance testing. Participants were over the age of 16 and fluent in English. All participants provided informed consent to participate in the study.

2.3. Measures

The *Self-Authenticity Measure* was developed through a consideration of literature on authenticity and valued living (Dahl, 2015; Harter, 2002; Hayes, 2004; Varga, 2014), particularly the framework proposed by Barney et al. (2019) which suggests novel measures should focus on

awareness of values, awareness of valued behaviours, and awareness of barriers to valued living. The research team developed 50 positively and negatively-worded items related to these three categories. Responses were indicated on a 5-point Likert Scale with higher scores indicating greater self-authenticity. Items were piloted by seven individuals from the LGBT + societies at the university who were given the list of items and were asked to provide brief qualitative feedback on them. This feedback was considered and general revisions were made to improve clarity, sensitivity, and appropriateness.

The *Authenticity Scale* (Wood et al., 2008) measures authenticity through 12 items grouped into the three subscales: authentic living, accepting external influences, and self-alienation. Higher scores indicate greater authenticity. It was included to assess convergent and incremental validity of the SAM.

The *Brief Fear of Negative Evaluation Scale* (Leary, 1983) measures fear of negative evaluation through 12 items. The original paper (ibid.) reports excellent internal consistency ($\alpha = 0.90$) and convergent validity with social anxiety ($r = 0.35$) and interaction anxiety ($r = 0.32$). Higher scores indicate greater fear of negative evaluation. It was included to assess convergent validity of the SAM.

The short-form *Depression, Anxiety, Stress Scale* (Antony et al., 1998) measures psychological distress through 21 items grouped into three subscales: depression, anxiety, and stress. The original paper (ibid.) reports good to excellent internal consistency ($\alpha = 0.87$ to 0.94) and convergent validity with other measures of depression ($r = 0.62$ to 0.79) and ($r = -0.71$ to -0.85). Although it can be used as three individual measures, the authors suggest a composite score can be calculated and used as a general measure of negative emotional symptoms (University of New South Wales, 2023). Higher standardised z-scores indicate greater psychological distress. It was included to assess concurrent validity of the SAM.

The *Rosenberg Self-Esteem Scale* (Rosenberg, 1965) measures self-esteem through 10 items. The original paper (ibid.) reports excellent internal consistency ($\alpha = 0.92$). Higher scores indicate greater self-esteem. It was included to assess concurrent validity of the SAM.

The *Comprehensive Assessment of Acceptance and Commitment Therapy* (Francis et al., 2016) measures psychological flexibility through 23 items grouped into three subscales: openness to experience, behavioural awareness, and valued action. The original paper (ibid.) reports good to excellent internal consistency for each subscale ($\alpha = 0.87$ to 0.90 ; composite $\alpha = .91$) and concurrent and convergent validity with measures of depression ($r = 0.65$), anxiety ($r = 0.57$), stress ($r = 0.57$), and experiential avoidance ($r = 0.79$). Higher scores indicate greater psychological flexibility. It was included to assess the relationship between psychological flexibility processes and self-authenticity.

The *Engaged Living Scale-9* (Trindade et al., 2016) measures engaged living through nine items grouped into two subscales: valued living and life fulfilment. The original paper (ibid.) reports good internal consistency for both subscales ($\alpha = 0.76$ to 0.89 ; composite $\alpha = .88$) and concurrent and convergent validity with quality of life ($r = 0.59$), depression ($r = -0.53$), anxiety ($r = -0.36$), stress ($r = -0.42$), and a previous measure of valued living ($r = 0.37$). Higher scores indicate greater engaged living. It was included to assess the relationship between psychological flexibility processes and self-authenticity.

2.4. Procedure

Participants clicked the study link which took them to the information sheet, online consent form, demographics questionnaire, and study measures. Participants were debriefed and entered into a prize draw to win one of five £20 Amazon vouchers. After seven days, participants from subsample 1 were invited to complete the SAM again for the time 2 datapoint ($n = 262$; days between actual completions $M = 9.68$, $SD = 3.15$).

2.5. Analysis

Analyses were completed using IBM SPSS version 26. Exploratory factor analysis (EFA) using principal axis factoring was used to identify the factor structure of the SAM. As scale means and totals were approximately normally distributed, test-retest reliability and validity were assessed using Pearson's r correlation coefficient. Cronbach's alpha was used to assess internal consistency of items. Following normality testing, hierarchical linear regressions were used to assess incremental validity of the SAM. CFA was completed using IBM AMOS version 26.

3. Results

A descriptive summary of all participants is presented in Table 1. A relatively even number of heterosexual ($n = 365$), gay/lesbian ($n = 367$), and bisexual ($n = 341$) people participated. Larger percentages of high school graduates, university graduates, employed workers, and full-time students participated. The sample was generally non-religious although a sizeable percentage identified as Christian. Ninety percent of the sample originated from North America and Europe and over 75% were Caucasian. Those who participated at both time points reported significantly higher self-authenticity ($t = 2.35$, $p = .02$) suggesting some bias, likely due to the self-selecting nature of the sample.

3.1. Factor structure of the SAM

Kaiser-Meyer-Olkin (0.963) and Bartlett's ($\chi^2(1128) = 17,654.23$, $p < .001$) tests suggested the data from subsample 1 (the sexual minority participants) were adequate for EFA, with the parallel analysis engine developed by Patil et al. (2007) suggesting a four-factor solution. The four-factor solution using direct oblimin rotation (as we expect factors to correlate) accounted for 49.50% of the initial cumulative variance and 45.13% of the cumulative variance following extraction. However, based on the recommendations from Guadagnoli and Velicer (1988) that a stable factor requires a minimum of four items loading greater than 0.6, factors three and four were removed resulting in a two-factor solution. Tabachnick et al. (2013) suggest removing items loading lower than 0.45, resulting in the removal of 19 items. Of the remaining 31 items, 16 demonstrated significant multicollinearity and were

Table 1
Demographic frequencies (N = 1073).

Demographic		Sexual minority (n = 708)		Heterosexual (n = 365)	
		n	%	n	%
Gender	Man	373	52.7	138	37.8
	Woman	284	40.1	224	61.4
	Non-binary	50	7.1	3	.8
Education	University	307	43.4	189	51.8
	High school	227	32.1	89	24.4
	College	130	18.4	71	19.5
	No schooling completing	34	4.8	9	2.5
Employment	Full-time employed	289	40.8	168	46.0
	Full-time student	189	26.7	68	18.6
	Part-time employed	108	15.3	47	12.9
	Unemployed	63	8.9	26	7.1
Religion	Other	54	7.6	53	14.5
	No religion	475	67.1	207	56.7
	Christianity	125	17.7	100	27.4
Continent	Other	99	13.9	52	14.3
	North America	412	58.2	165	45.2
	Europe	231	32.6	155	42.5
	Oceania	21	3.0	9	2.5
	South America	21	3.0	6	1.6
	Asia	19	2.7	26	7.1
Ethnicity	Africa	3	.4	3	.8
	Caucasian	546	77.1	266	72.9
	Other	147	20.7	88	24.1

Table 2
Descriptive statistics and intercorrelations of the SAM.

Construct	Time	n	M	SD	Skew	Kurtosis	α	SAM r	ISA r
SAM	1	698	3.43	.69	-.15	-.48	.88		
	2	258	3.43	.66	-.16	-.46	.89		
ISA	1	700	3.63	.75	-.43	-.32	.84	.866*	
	2	260	3.61	.73	-.30	-.49	.86	.887*	
ESA	1	706	3.22	.82	-.07	-.63	.83	.889*	.541*
	2	260	3.26	.77	-.12	-.49	.84	.899*	.595*

Note. SAM = Self-Authenticity Measure; ISA = Internal Self-Authenticity; ESA = External Self-Authenticity; *p < .001.

systematically removed, resulting in 15 final items. The two factors (eigenvalues of 5.767 and 1.717 respectively) accounted for 49.89% of the initial cumulative variance and 42.43% of the cumulative variance following extraction. Factor 1 (eight items) relates to understanding what one wants from life and knowing and being one’s self, and was labelled internal self-authenticity (ISA). Factor 2 (seven items) relates to being one’s self around and not compromising who one is for others, and was labelled external self-authenticity (ESA). Subscale scores were computed by calculating the mean of item scores and overall self-authenticity was computed by calculating the mean of both subscale mean scores in turn. See Table 2 for descriptive statistics and intercorrelations of the SAM and its two subscales. The final version of the SAM can be found in Appendix A and on The Open Science Framework using the following link: <https://osf.io/yfrp6>.

3.2. Validity and reliability of the SAM

Using subsample 1, the SAM and its subscales demonstrated good internal consistency (α = 0.83 to 0.89) and good to excellent test-retest reliability (r = 0.874 to 0.919). Convergent validity was found between the SAM and its subscales and the Wood et al. (2008) Authenticity Scale (r = 0.698 to 0.843) and fear of negative evaluation (r = -0.509 to -0.696). Using Fisher’s r to z transformation, fear of negative evaluation is significantly more related to ESA than ISA (z = 3.39, p < .001). Concurrent validity was also demonstrated between the global and subscale scores from the SAM and depression (r = -0.484 to -0.643), anxiety (r = -0.373 to -0.458), stress (r = -0.420 to -0.509), and self-esteem (r = 0.576 to 0.755). Furthermore, moderate to strong correlations were found between the SAM and its subscales and psychological flexibility processes (r = 0.669 to 0.804) and engaged living

processes (r = 0.633 to 0.834), with the values-related processes being the strongest correlates. See Table 3 for descriptives and correlations with further variables.

To assess incremental validity, using subsample 1, both subscales of the SAM (ISA and ESA) were entered into hierarchical linear regressions using the ‘enter’ method to ascertain whether they explain unique variance in depression, anxiety, stress, and self-esteem, over and above the subscales of the Wood et al. (2008) Authenticity Scale (authentic living, self-alienation, and accepting external influences). For each model, at step 1 the Authenticity Scale subscales explained significant variance (all p < .001) in depression (R² = 0.432), anxiety (R² = 0.251), stress (R² = 0.307), and self-esteem (R² = 0.519). At step 2, the SAM subscales explained significantly increased variance (all p < .001) in depression (ΔR² = 0.079), anxiety (ΔR² = 0.029), stress (ΔR² = 0.015), and self-esteem (ΔR² = 0.079). Considering full models, depression was predicted by self-alienation (β = 0.37, p < .01), ISA (β = -0.39, p < .01), and ESA (β = -0.10, p = .02) with authentic living becoming non-significant. Anxiety was predicted by self-alienation (β = 0.30, p < .01) and ESA (β = -0.26, p < .01) with authentic living and accepting external influences becoming non-significant. Stress was predicted by self-alienation (β = 0.34, p < .01) and ESA (β = -0.18, p < .01) with accepting external influences becoming non-significant. Self-esteem was predicted by self-alienation (β = 0.40, p < .01), accepting external influences (β = -0.21, p < .01), and ISA (β = 0.40, p < .01).

To assess construct validity and measurement invariance, a CFA of the SAM was conducted using subsample 2 (the heterosexual participants; see Fig. 1), demonstrating adequate goodness of fit (CFI = 0.921, TLI = 0.907, SRMR = 0.05, RMSEA = 0.07) when compared with Kline’s (2015) adequacy criteria (CFI >0.90; TLI >0.90; SRMR <0.08; RMSEA <0.08).

Table 3
Descriptive statistics and correlations of further variables with the SAM.

Time	Construct (Psychometric)	n	M	SD	Skew	Kurtosis	α	SAM r	ISA r	ESA r	
1	Authenticity (AS)	703	57.64	14.72	-.30	-.61	.90	.843*	.698*	.777*	
	Authentic living	706	22.01	4.42	-.78	.21	.81	.676*	.574*	.610*	
	Accepting external influences	707	14.77	6.02	.13	-.70	.87	-.708*	-.506*	-.725*	
	Self-alienation	706	13.63	7.17	.39	-1.04	.88	-.725*	-.661*	-.612*	
	Psychological distress (DASS)	690	.01	.88	.50	-.61	.94	-.609*	-.544*	-.520*	
	Depression	701	.02	.99	.46	-1.03	.93	-.640*	-.643*	-.484*	
	Anxiety	700	.02	.99	.88	.04	.84	-.458*	-.373*	-.426*	
	Stress	699	.01	.99	.37	-.77	.86	-.509*	-.420*	-.467*	
	Psychological flexibility (CompACT)	694	75.84	25.91	.09	-.57	.93	.804*	.738*	.669*	
	Valued action	700	33.77	9.05	-.77	.54	.89	.804*	.808*	.596*	
	Openness to experience	705	27.22	13.26	.31	-.70	.87	.660*	.564*	.592*	
	Behavioural awareness	705	14.92	7.75	.13	-1.00	.86	.626*	.564*	.533*	
	Engaged living (ELS-9)	702	28.09	8.21	.11	-.74	.91	.834*	.824*	.633*	
	Valued living	705	17.20	4.32	-.26	-.44	.81	.826*	.842*	.600*	
	Life fulfilment	705	10.88	4.39	.32	-.90	.88	.745*	.709*	.592*	
	2	Fear of negative evaluation (BFNES)	261	38.79	12.96	-.11	-1.11	.95	-.687*	-.509*	-.696*
		Self-esteem (RSES)	260	17.05	7.60	-.01	-.95	.94	.737*	.755*	.576*

Note. SAM = Self-Authenticity Measure; ISA = Internal Self-Authenticity; ESA = External Self-Authenticity; AS = Authenticity Scale; DASS = Depression, Anxiety, Stress Scale; CompACT = Comprehensive Assessment of Acceptance and Commitment Therapy; ELS-9 = Engaged Living Scale-9; BFNES = Brief Fear of Negative Evaluation Scale; RSES = Rosenberg Self Esteem Scale; *p < .001.

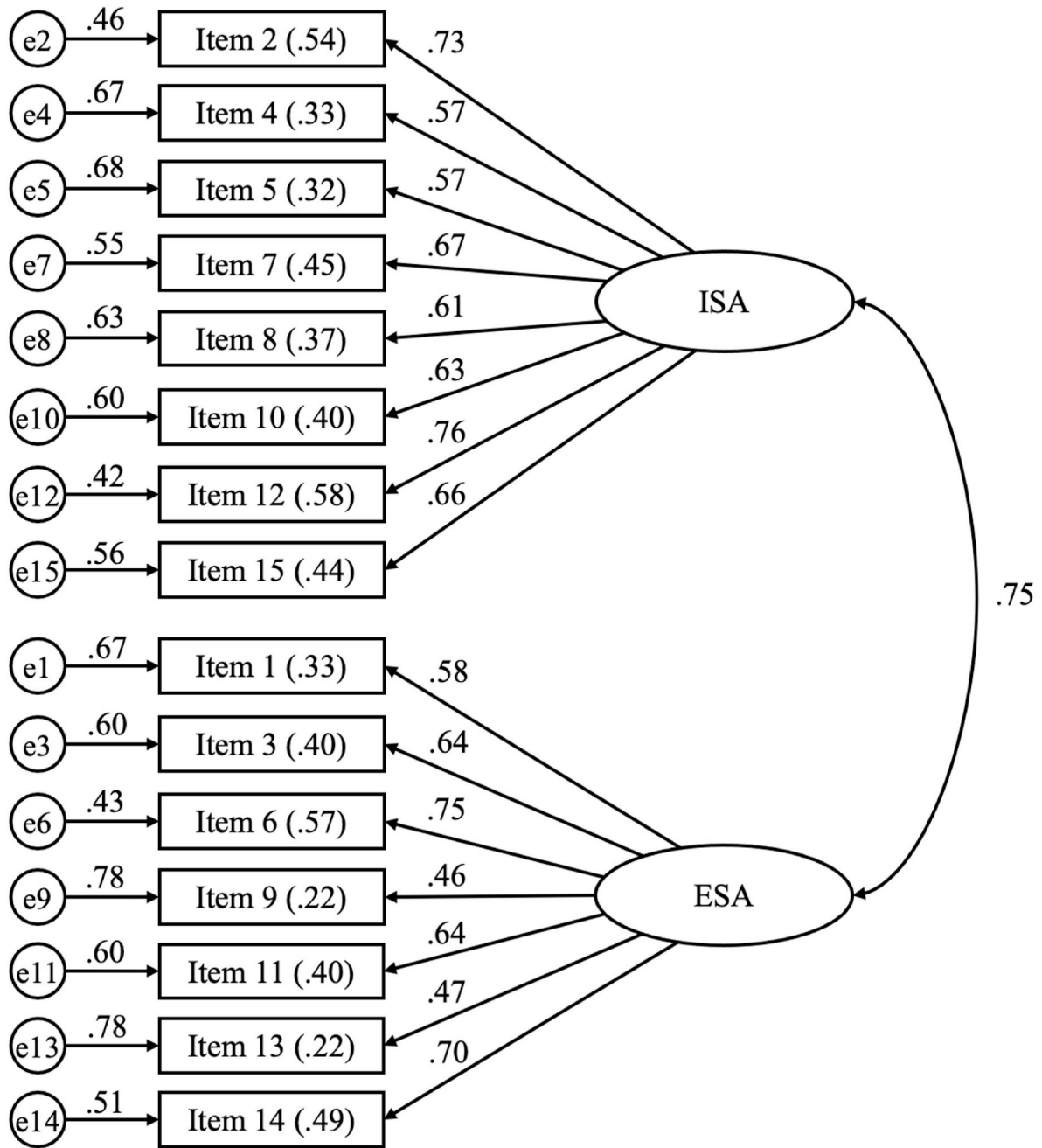

Fig. 1. CFA of the SAM using structural equation modelling.

4. Discussion

A novel psychometric measure of self-authenticity is warranted as existing measures each suffer potential issues. For example, the Authenticity Inventory (Kernis & Goldman, 2006) lacks measure development detail and face validity, the Authenticity Scale (Wood et al., 2008) is underpowered and contains theoretically unstable factors, and the Moscow Authenticity Scale (Reznichenko et al., 2021) requires further validation work. Furthermore, since the development of the earlier measures, the concept of values-based living has been given increased attention within psychotherapy research (Barney et al., 2019; Dahl, 2015; Hayes et al., 2011). As such, a more up-to-date consideration of values may suggest the potential for novel wording in authenticity items.

The factor structure of the SAM did not follow the proposed three-factor model by Barney et al. (2019; i.e., awareness of values, awareness of valued behaviours, and awareness of barriers to living in line with one’s values), but instead initially loaded across four factors, two of which were removed for lacking sufficiently loading items. After their removal, the remaining items loaded around two distinct factors related to knowing and being one’s self and being one’s self around others. The SAM strongly converged with the Wood et al. (2008) measure of authenticity, suggesting the SAM is validly measuring aspects of authenticity. The ESA subscale has a significantly stronger relationship with fear of negative evaluation than does ISA, suggesting that ESA is indeed more attuned to measuring the extent to which society affects individuals’ self-authenticity – a finding that is broadly in line with the theoretical assumptions that society plays a key role in how

self-authenticity is shaped (Guignon, 2008; Stefan, 2016; Varga, 2014; Wood et al., 2008). As with previous assertions (Harter, 2002; Sutton, 2020; Varga, 2014), the SAM correlated with psychological distress and self-esteem suggesting that self-authenticity may be predictive of these and may thus have some clinical relevance; future work should test potential causal pathways. The SAM also demonstrates good to excellent internal consistency and test-retest reliability suggesting the items are coherently and consistently measuring self-authenticity at least over a short period of time.

Incremental validity checks found that ISA better predicted depression and self-esteem over the Wood et al. (2008) Authenticity Scale subscales, particularly the authentic living subscale which became non-significant. However when predicting anxiety and stress, the self-alienation subscale of the Authenticity Scale remained the strongest predictor, although ESA was also significant, suggesting the Authenticity Scale still holds some utility in predicting these outcomes. Finally, CFA provided evidence of construct validity and of configural invariance (a type of measurement invariance) across samples differing by sexuality. Future research is needed with a wider range of samples and demographics to fully establish measurement invariance.

The present study also sought to assess the relationships between the SAM and psychological flexibility processes, given that self-authenticity is related to living in line with one’s values (Hayes, 2004). It is promising to see moderate to strong correlations with such variables, particularly those related to values, providing further evidence of the validity of the SAM and tentatively suggesting that ACT (an empirically tested therapeutic framework) may be a ready means by which to increase self-authenticity.

4.1. Limitations

Despite these positive findings we also acknowledge some limitations of the study. The development of the SAM is based on one study using two subsamples, and therefore confidence in the SAM would be further demonstrated with further validation studies, particularly using different demographic samples to test for measurement invariance. Furthermore, a more robust measurement invariance analysis is needed, particularly one that is based on concrete hypothesis testing, ideally adopting an Item Response Theory framework. Given that 90% of the sample originated from North America and Europe and that over 75% were Caucasian, and given that authenticity may be viewed differently across cultures (Varga, 2014), future work should seek to confirm the model within different geographical, ethnic, and cultural contexts.

Appendix A

The Self-Authenticity Measure

Below, you’ll find a number of statements about who you are as a person. We are looking for your immediate reaction to each statement. Read each carefully, but don’t over-think them. As you read each statement, mark how much you personally agree or disagree with them. There are no right or wrong answers.

	1 Completely disagree	2 Disagree	3 Neutral	4 Agree	5 Completely agree
1. Even when I disagree with those around me, I pretend to agree					
2. I know how I want to live my life					
3. I try to be myself in front of people I know					
4. I am powerless to change my behaviour					
5. I believe my life has meaning					
6. I pretend to be someone I am not when in front of others					
7. I know how to achieve my goals					
8. If I really want something, I can persevere despite problems					

(continued on next page)

Finally, despite our correlation evidence, we do not wish to make concrete assertions that psychological flexibility will be helpful in predicting and influencing individuals’ levels of self-authenticity. These preliminary cross-sectional findings need further testing, perhaps through a well-designed ACT trial, to assess whether alterations in psychological flexibility processes affect self-authenticity.

5. Conclusion

Our novel measure of self-authenticity offers some advantages over its predecessors, namely that it is short, was developed using a greater number of participants, and meets established cut-offs for psychometric stability. The SAM demonstrates a strong factor structure, and evidence of moderate to strong convergent, concurrent, incremental, construct validity, and measurement invariance across two groups established on the basis of sexuality, as well as good to excellent internal consistency and test-retest reliability. Our study established significant relationships between self-authenticity and living in line with one’s values, demonstrating a large degree of overlap between the two constructs, and tentatively suggesting that ACT-based interventions may be of some use in helping individuals to increase their levels of self-authenticity. The SAM appears to meet standard psychometric cut-offs for use as a research measure. Further work would be needed to establish it for clinical diagnostic use and to test further its measurement invariance across other demographic characteristics.

Funding details

This programme of work was not in receipt of external funding.

CRedit authorship contribution statement

T. Cartwright: Conceptualization, Methodology, Data curation, Writing – original draft, preparation. **L. Hulbert-Williams:** Conceptualization, Methodology, Supervision, reviewing, validating, and editing. **G. Evans:** Supervision, reviewing, and editing. **N. Hulbert-Williams:** Supervision, reviewing, and editing.

Declaration of competing interest

The authors declare that they have no known competing financial interests or personal relationships that could have appeared to influence the work reported in this paper.

(continued)

	1 Completely disagree	2 Disagree	3 Neutral	4 Agree	5 Completely agree
9. Society stops me from being who I want to be					
10. I know what is important to me and what is not					
11. Other people greatly influence my actions					
12. I pursue what is important to me					
13. I do not care what strangers think about me					
14. I conform to others' standards					
15. I do not know what I want to accomplish in my life					

Scoring Instructions.

- Items 1, 4, 6, 9, 11, 14, and 15 are reverse scored.
- Internal Self-Authenticity is calculated by finding the mean of items 2, 4, 5, 7, 8, 10, 12, and 15.
- External Self-Authenticity is calculated by finding the mean of items 1, 3, 6, 9, 11, 13, and 14.

This psychometric tool, and associated documents are licensed under a Creative Commons Attribution-ShareAlike 4.0 International License: <http://creativecommons.org/licenses/by-sa/4.0>. You may use it, share it, make derivative works, and share those, so long as you acknowledge the original authors using the citation above.

References

- Antony, M. M., Bieling, P. J., Cox, B. J., Enns, M. W., & Swinson, R. P. (1998). Psychometric properties of the 42-item and 21-item versions of the Depression Anxiety Stress Scales in clinical groups and a community sample. *Psychological Assessment, 10*(2), 176–181. <https://doi.org/10.1037/1040-3590.10.2.176>
- Barney, J. L., Lillis, J., Haynos, A. F., Forman, E., & Juarascio, A. S. (2019). Assessing the valuing process in Acceptance and Commitment Therapy: Experts' review of the current status and recommendations for future measure development. *Journal of Contextual Behavioral Science, 12*, 225–233. <https://doi.org/10.1016/j.jcbs.2018.08.002>
- Bond, M. J., Strauss, N. E., & Wickham, R. E. (2018). Development and validation of the Kernis-Goldman authenticity inventory-short form (KGAISF). *Personality and Individual Differences, 134*, 1–6. <https://doi.org/10.1016/j.paid.2018.05.033>
- Dahl, J. (2015). Valuing in ACT. *Current Opinion in Psychology, 2*, 43–46. <https://doi.org/10.1016/j.copsyc.2015.03.001>
- Digman, J. M. (1990). Personality structure: Emergence of the five-factor model. *Annual Review of Psychology, 41*(1), 417–440. <https://doi.org/10.1146/annurev.ps.41.020190.002221>
- Field, A. (2013). *Discovering statistics using IBM SPSS statistics (4th ed.)*. Sage.
- Flake, J. K., & Fried, E. I. (2020). Measurement schmeasurement: Questionable measurement practices and how to avoid them. *Advances in Methods and Practices in Psychological Science, 3*(4), 456–465. <https://doi.org/10.3389/fpsyg.2015.00309>
- Francis, A. W., Dawson, D. L., & Golijani-Moghaddam, N. (2016). The development and validation of the comprehensive assessment of acceptance and commitment therapy processes (CompACT). *Journal of Contextual Behavioral Science, 5*(3), 134–145. <https://doi.org/10.1016/j.jcbs.2016.05.003>
- Gardner, D. M., & Prasad, J. J. (2022). The consequences of being myself: Understanding authenticity and psychological safety for LGB employees. *Journal of Occupational and Organizational Psychology, 95*(4), 788–797. <https://doi.org/10.1111/joop.12399>
- Gendlin, E. T. (1984). The client's client: The edge of awareness. In R. L. Levant, & J. M. Shlien (Eds.), *Client-centered therapy and the person-centered approach. New directions in theory, research and practice* (pp. 76–107). New York: Praeger.
- Guadagnoli, E., & Velicer, W. F. (1988). Relation of sample size to the stability of component patterns. *Psychological Bulletin, 103*(2), 265–275. <https://doi.org/10.1037/0033-2909.103.2.265>
- Guignon, C. (2008). Authenticity. *Philosophy Compass, 3*(2), 277–290. <https://doi.org/10.1111/j.1747-9991.2008.00131.x>
- Harter, S. (2002) (Chapter 27): Authenticity. In C. R. Snyder, & S. J. Lopez (Eds.), *Handbook of positive psychology* (pp. 382–394). Oxford University Press.
- Hayes, S. C. (2004). Acceptance and commitment therapy, relational frame theory, and the third wave of behavioral and cognitive therapies. *Behavior Therapy, 35*(4), 639–665. [https://doi.org/10.1016/S0005-7894\(04\)80013-3](https://doi.org/10.1016/S0005-7894(04)80013-3)
- Hayes, S. C., Luoma, J. B., Bond, F. W., Masuda, A., & Lillis, J. (2006). Acceptance and commitment therapy: Model, processes and outcomes. *Behaviour Research and Therapy, 44*(1), 1–25. <https://doi.org/10.1016/j.brat.2005.06.006>
- Hayes, S. C., Strosahl, K. D., & Wilson, K. G. (2011). *Acceptance and commitment therapy: The process and practice of mindful change*. Guilford Press.
- Kernis, M. H., & Goldman, B. M. (2006). A multicomponent conceptualization of authenticity: Theory and research. *Advances in Experimental Social Psychology, 38*, 283–357. [https://doi.org/10.1016/S0065-2601\(06\)38006-9](https://doi.org/10.1016/S0065-2601(06)38006-9)
- Leary, M. R. (1983). A brief version of the fear of negative evaluation scale. *Personality and Social Psychology Bulletin, 9*, 371–376. <https://doi.org/10.1177/0146167283093007>
- Levitt, H. M., Horne, S. G., Herbitter, C., Ippolito, M., Reeves, T., Baggett, L. R., ... Geiss, M. (2016). Resilience in the face of sexual minority stress: "Choices" between authenticity and self-determination. *Journal of Gay & Lesbian Social Services, 28*(1), 67–91. <https://doi.org/10.1080/10538720.2016.1126212>
- Meyer, I. H. (1995). Minority stress and mental health in gay men. *Journal of Health and Social Behavior, 36*(1), 38–56. <https://doi.org/10.2307/2137286>
- Patil, V. H., Singh, S. N., Mishra, S., & Donovan, T. (2007). Parallel analysis engine to aid determining number of factors to retain. Available from: <https://analytics.gonzaga.edu/paralleleengine>.
- Pietikainen, P. (2002). Utopianism in psychology: The case of wilhelm reich. *Journal of the History of the Behavioral Sciences, 38*(2), 157–175. <https://doi.org/10.1002/jhbs.10034>
- Plumb, J. C., Stewart, I., Dahl, J., & Lundgren, T. (2009). In search of meaning: Values in modern clinical behavior analysis. *The Behavior Analyst, 32*(1), 85–103. <https://doi.org/10.1007/BF03392177>
- Reilly, E. D., Ritzert, T. R., Scoglio, A. A., Mote, J., Fukuda, S. D., Ahern, M. E., & Kelly, M. M. (2018). A systematic review of values measures in acceptance and commitment therapy research. *Journal of Contextual Behavioral Science, 12*, 290–304. <https://doi.org/10.1016/j.jcbs.2018.10.004>
- Reznichenko, S. I., Nartova-Bochaver, S. K., & Irkhin, B. D. (2021). Do authentic people care about the environment? A view from two paradigms. *Psychology in Russia, 14* (3), 81–102. <https://doi.org/10.11621/PIR.2021.0306>
- Rosenberg, M. (1965). *Society and the adolescent self-image*. Princeton University Press.
- Rowan, J. (2000). The self, the field and the either-or. *International Journal of Psychotherapy, 5*(3), 219–226. <https://doi.org/10.1080/13569080020012471>
- Sheldon, K. M., & Kasser, T. (2001). Goals, congruence, and positive well-being: New empirical support for humanistic theories. *Journal of Humanistic Psychology, 41*(1), 30–50. <https://doi.org/10.1177/0022167801411004>
- Stefan, I. (2016). Authenticity of human behavior in freud and heidegger. *Agathos, 7*(2), 50–70.
- Sutton, A. (2020). Living the good life: A meta-analysis of authenticity, well-being and engagement. *Personality and Individual Differences, 153*, Article 109645. <https://doi.org/10.1016/j.paid.2019.109645>
- Tabachnick, B. G., Fidell, L. S., & Ullman, J. B. (2013). *Using multivariate statistics (6th ed.)*. Pearson.
- Trindade, I. A., Ferreira, C., Pinto-Gouveia, J., & Nooren, L. (2016). Clarity of personal values and committed action: Development of a shorter engaged living scale. *Journal of Psychopathology and Behavioral Assessment, 38*(2), 258–265. <https://doi.org/10.1007/s10862-015-9509-7>
- University of New South Wales. (2023). *DASS FAQ (frequently asked questions)*. September 11 <http://www2.psy.unsw.edu.au/dass/DASSFAQ.htm>.
- Varga, S. (2014). *Authenticity. The Encyclopedia of political thought*.
- de Winter, J. C. F., Dodou, D., & Wieringa, P. A. (2009). Exploratory factor analysis with small sample sizes. *Multivariate Behavioral Research, 44*(2), 147–181. <https://doi.org/10.1080/00273170902794206>
- Wood, A. M., Linley, P. A., Maltby, J., Baliousis, M., & Joseph, S. (2008). The authentic personality: A theoretical and empirical conceptualization and the development of the authenticity scale. *Journal of Counseling Psychology, 55*(3), 385–399. <https://doi.org/10.1037/0022-0167.55.3.385>